

# 5TH WHEEL

## MOTOR ASSEMBLY EXPLODED VIEW

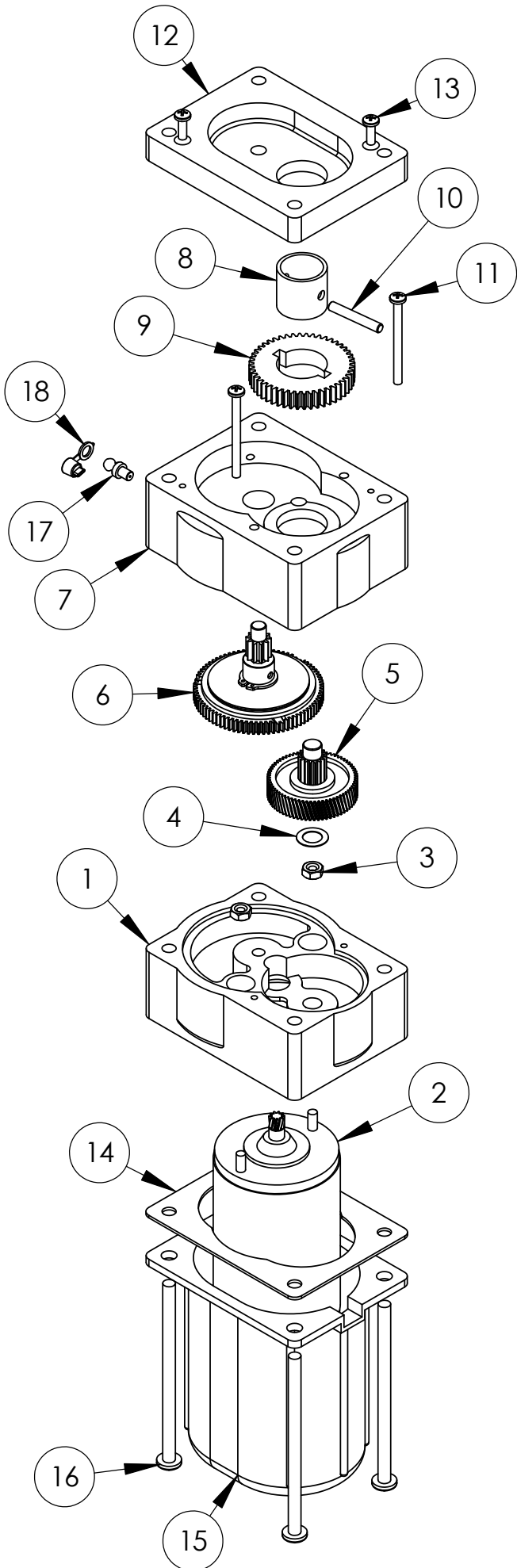

NO.	PART NO.	DESCRIPTION
1	17-741069	HOUSING-MOTOR
2	17-840016.001	MOTOR-12 VOLT
3	17-113303	NUT-#10 KEP
4	17-141010.008	WASHER-3/8" X .015
5	17-840028	NYLON GEAR ASSEMBLY
6	17-840005.001	CLUTCH ASSEMBLY
7	17-741032	HOUSING-CLUTCH
8	17-741023	SLEEVE-DRIVE
9	17-741022	GEAR-DRIVE
10	17-741021	PIN-DRIVE
11	17-Y-12925	SCREW-#8 X 2"
12	17-741042	PLATE-HOUSING
13	17-Y-12926	SCREW-#8 X 1/2"
14	17-141008.003	GASKET
15	17-741622	COVER-MOTOR
16	17-113369	SCREW-1/4-20 X 4.25" HEX
17	17-143230	FITTING-GREASE
18	17-143231	CAP-GREASE

17-840007.003  
COMPLETE MOTOR GEAR  
ASSEMBLY  
INCLUDES PARTS 1-13, 17,18